



NIPPON CAREER
KP-150
CATALOG

KP-150



KP-150

Slicer with Automatic Packer

Ultimate Labor Savings

Enables one worker to do the labor of four.
Achieves drastic labor reductions.
Automates sliced meat production, reduces labor.



KP-150

KP-150 features

- **Drastic improvements in material handling**
Just leave the tray packing to the machine! The KP-150 can supply trays and material without stopping.
- **High precision tray packing**
The conveyor end extends and retracts during packing to ensure meat is positioned evenly on each tray.
- **Drastic increase in material yield rate**
The proven band knife and swinging slice system from our AX and AZ models drastically increases yield rate.
- **Reduces discrepancies in slice volume**
Gapless meat feeding ensures stable sliced meat packing volumes on trays.

Four dimension feed conveyor Conveyor extending Conveyor retracting

- Four dimension conveyor delivers end-piece materials neatly.
- Nippon Career's transfer rollers automatically pack sliced meat from the conveyor onto trays.
- The conveyor extends and retracts to pack meat evenly onto trays.

Max. 250mm

- Trays are fed automatically to the machine after being set in the tray-magazine.
- Packing coordinates are set according to tray size.

[Specifications]

Model	KP-150	
Temperature range	-1~+5°C (Optimum temp. +2~3°C)	
Max. material dimensions	W150 × H155 × L800mm	
Slicing thickness	1~5mm	
Slicing speed	20~88slices/min.	
Useable trays / sizes	PSP trays/ W196/193 × L100~250 × H~40(mm)(*1)	
Throughput (example)(*2)	100g: 40packs/min. 200g: 22packs/min.	300g: 14packs/min. 400g: 11packs/min.
Pack weight (ref.)	50~600g(*3)	
Drive/water supply	AC200V 3.105kW/Connects to water service pipe	
Air pressure, vol.	0.5Mpa 500L/min.	
Dimensions	W1765 × L2195 × H1930mm	

*1: Depending on the material and shape of the tray, it may not be applicable.
*2: Theoretical value given slice thickness of 2.3mm.
*3: This machine is not equipped to measure weight.

[Dimensions]

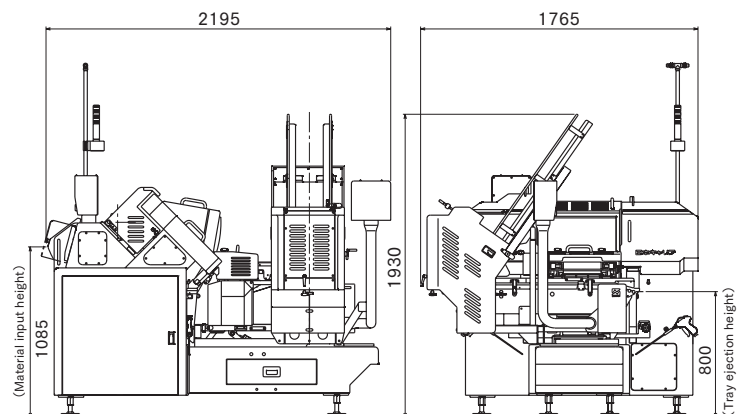

Challenging "Perfection"
NIPPON CAREER INDUSTRY CO., LTD.

980-5 Higashi habu-machi, Matsuyama City, Ehime, Japan. 7918043
TEL: +81-89-908-7373
E-mail: eigyou-oversea@nippon-career.co.jp
<https://www.nippon-career.co.jp>

Agent: