



NIPPON CAREER  
BUTTER FLAKER  
CATALOG

# BUTTER FLAKER



**BUTTER FLAKER**  
BF-300

# Flaker specialized for cutting dairy products in the freezing temperature range [-20°C]

Introducing a new addition to our Flaker series, which delivers top-level product quality, safety and sanitation

- Our original rotor shape reduces surface area with direct contact with raw materials in response to their tendency to cling when the temperature rises. Achieves enhanced washability as well.
- Cross-cut configuration with wrapping knife blades achieves highly efficient cutting.
- Compact in size, yet supports raw material dimensions up to **L 600 x W 380 x H 300 mm**.
- Automatic pressurization enables continuous insertion of raw materials. Sensor-equipped work platform ensures safe distance.
- Casters ensure smooth movement.
- Features brake motor, like the rest of our Flaker series, to stop spinning of rotor when unit is stopped or safety cover is released.
- Cover for rotor section features damper to hold it in place when released for greater safety.
- Inner walls of discharge chute can optionally be outfitted with a heater.

## [Dimensions]

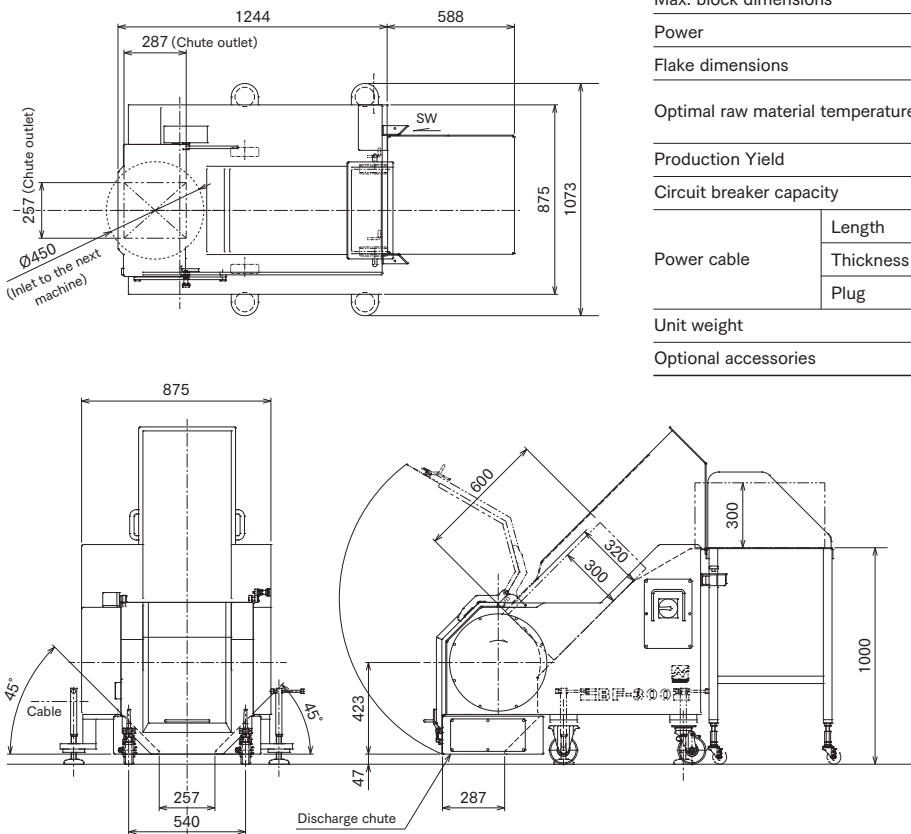

## [Specifications]

Model	BF-300 (dairy products flaker)	
Max. block dimensions	L 600 x W 380 x H 300 (mm)	
Power	Three-phase 200V 3.7 kW *with brake motor	
Flake dimensions	67.5 x [3/4/5/6/7/8] (mm)(adjustable by means of liner)	
Optimal raw material temperature	-20° C and above (May vary somewhat depending on raw material)	
Production Yield	1,300-3,000 kg/hr(May vary depending on raw material)	
Circuit breaker capacity	Three-phase 200V 40A	
Power cable	Length	5m
	Thickness	8.0mmφ
	Plug	N/A
Unit weight	755 kg	
Optional accessories	Discharge chute (with/without heater)	



Butter cut into flakes



Challenging "Perfection"  
**NIPPON CAREER INDUSTRY CO., LTD.**

Agent:

980-5 Higashi habu-machi, Matsuyama City, Ehime, Japan. 7918043  
TEL: +81-89-908-7373  
E-mail: eigyou-oversea@nippon-career.co.jp  
<https://www.nippon-career.co.jp>