

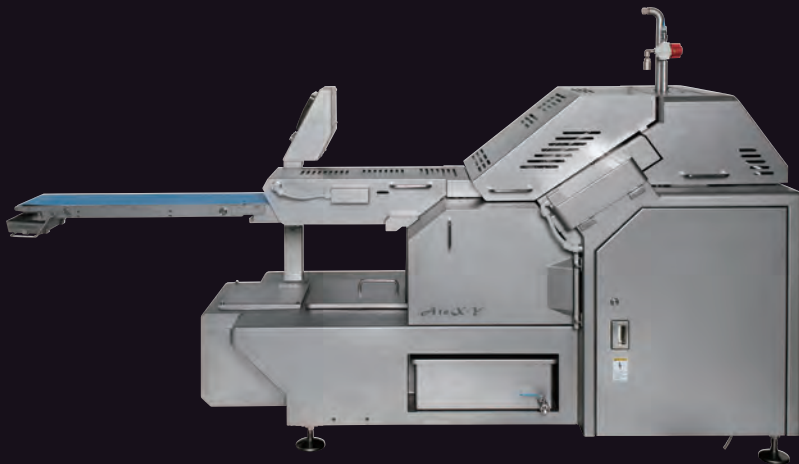

NIPPON CAREER  
AXY-201CE  
CATALOG

# AXY-201CE



**AXY-201CE**  
Compact Slicer



# Compact slicer for fresh meat

## ① Dramatically improved product appeal

- Automated sharpening and cleaning of the band knife during operation maintains uniform cutting thickness and smooth cut surfaces.
- Tempering is not necessary even for soft meats in the chilled temperature range. Enables reliable slicing.

## ② Stunning material yield rate

- Accurately slices individual raw materials even near the edges, enabling complete utilization from end to end without waste.
- Delivers solid slicing performance with scissor-like cutting ability. Does not permit results like torn off scraps.

## ③ Profitability-minded operating efficiency

- Enables continuous feeding of raw materials. Sliced meat is reliably lined up on the conveyor, enabling continuous work without stopping the machinery. Touch screen controls simplify operation as well, and no tools are required to disassemble the machinery for cleaning.

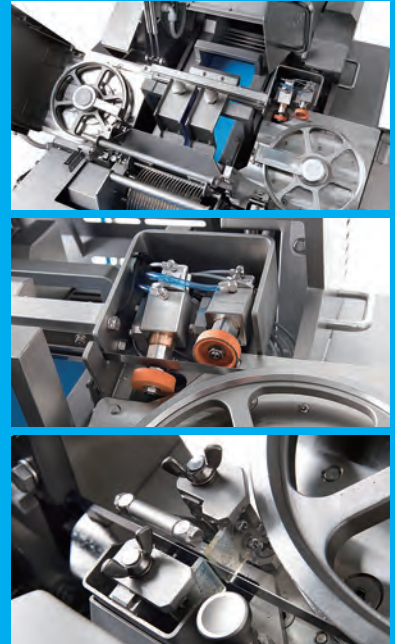

### [Spec.]

|                                |                                    |
|--------------------------------|------------------------------------|
| Model                          | AXY-201CE                          |
| Applicable Temperature         | -1°C~+5°C                          |
| Function                       | Slicing, Shingling                 |
| Max. dimension of raw material | W200×H100×L600mm                   |
| Input port                     | 1 or 2row<br>(Removable partition) |
| Slicing thickness              | 1~25mm                             |
| Max rpm                        | 70                                 |
| Conveyor                       | W230×L940mm                        |
| Machine dimension              | W1080×L2270×H1710mm                |
| Weight                         | 965                                |
| Power                          | Three phase 380V<br>1.44kW         |
| Air                            | 0.5MPa<br>260 ℓ /min.              |
| Water                          | 0.2MPa and higher                  |

### [Input Port]

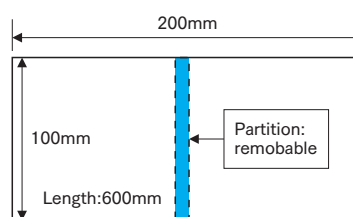

### [Dimensions]

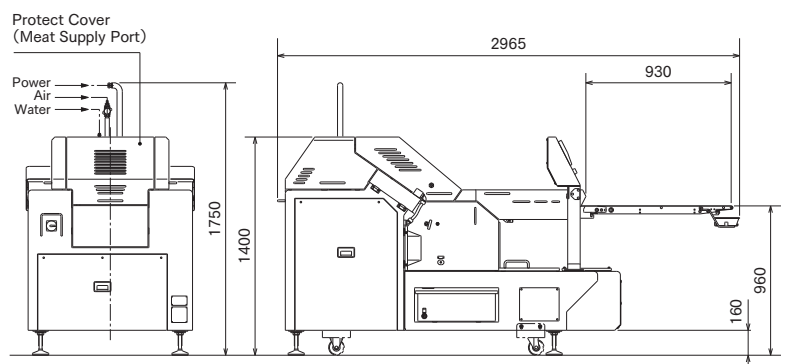

Challenging "Perfection" —————  
**NIPPON CAREER INDUSTRY CO., LTD.**

980-5 Higashi habu-machi, Matsuyama City, Ehime, Japan. 7918043  
 TEL: +81-89-908-7373  
 E-mail: eigyou-oversea@nippon-career.co.jp  
<https://www.nippon-career.co.jp>

Agent: