

# MINCE PACKER LINE

## MINCE PACKER

Model	MP-117 (standard specs)	
	MP-117C (with ejection conveyor)	
Drive 3phase 200V	Material conveyor	0.1kW
	Tray conveyor	0.2kW
	Feeding scraper	0.2kW
	Material width adjusting guide/ Tray width adjusting guide	0.1kW
	Pad arm	0.2kW
	Peeling unit tray conveyor	0.2kW
	Ejection conveyor (MP-117 only)	0.03kW
Material conveyor speed	13~126mm/sec	
Conveyor belt width	180mm	
Useable tray sizes	W100~210×L120~250×H27~40mm	
Processing ability	Weight of packs	80~800g/pack
	Cutting length	50~200mm
	Width of material width adjusting guide	63~160mm
	Processing ability	4200pack/h(MAX)
Tray ejection height	MP-117 : 635mm MP-117C : 750mm	
Air	Air supply pressure 0.5MPa Air consumption 350L/mi	
Dimensions	MP-117 : W2035×D1676×H1750mm	
	MP-117C : W2470×D1676×H1750mm	
Weight	900kg	

## TWIN CHOPPER

Model	TC-093	
Cylinder size	#22	#32
Drive 3phase 200V	For charging	2.2kW
	For paddles	5.5kW
Processing ability	220~560kg/h	430~1130kg/h
	190~470kg/h(#12 equivalent)	
Tub capacity	80L (full water volume)	
Charging screw rpm (inverter controlled)	64~167rpm	82~218rpm
Paddle rpm (inverter controlled)	7~29rpm	
Dimensions	W1217×D1215×H1640mm	
Weight	615kg	
Notes	External automatic bone collector equipped standard	

## MINCE PACKER

Model	MP-083	
	Cutter	Chopper
Drive	3相 200V 0.1kW	3相 200V 2.2kW
Processing ability	—	150~440kg/h (Theoretical value with continuous feed)
Tub capacity	—	48L (with aux. hopper)
Dimensions	W2570×D885×H1272mm	W640×D883×H1460mm
Weight	250kg	240kg
Notes	Air supply pressure: 0.5MPa Air consumption: 120L/min Optional: External automatic bone collector Plate diameter: #22 (82mm)	

### [Dimensions] MP-117/117C

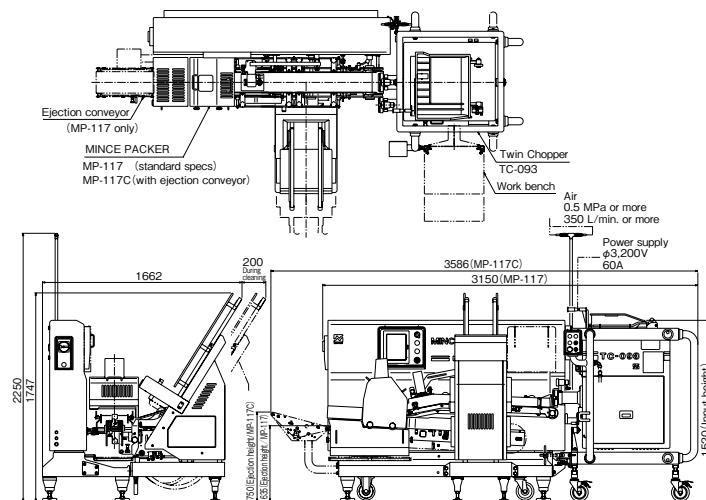

### MP-083

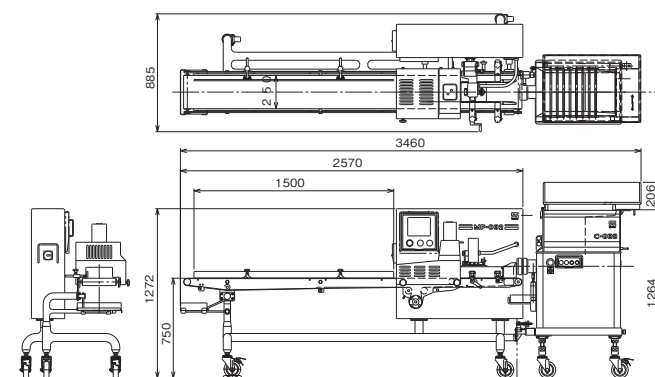

Agent:



980-5 Higashi habu-machi, Matsuyama City, Ehime, Japan. 7918043  
TEL: +81-89-908-7373  
E-mail: eigyou-oversea@nippon-career.co.jp  
https://www.nippon-career.co.jp

Please be aware that product specifications may be changed without notice in order to improve product performance.

Ver.2022.11



NIPPON CAREER  
MINCE PACKER® LINE  
CATALOG



**MINCE PACKER LINE**  
MP-117 / TC-093 / MP-083

MINCE PACKER LINE

# Big on Labor Savings, Gentle on Meat

Cuts ground meat continuously delivered by a grinder to fixed lengths and packs onto trays.

[Fully Automatic Line]

Dedicated Twin Chopper **TC-093** / Mince Packer **MP-117**  
(With tray dispenser)



- **Uniform packing volumes**  
Uniform flow of ground meat is cut at fixed lengths and packed onto trays. Achieves packs with little variation in packing weight.
- **Improved product appearance**  
Ground meat grains are aligned, improving product appearance.
- **Touch panel operation for product settings**  
Can save settings for up to 11 products by pack weight. Guides automatically adjust for each product setting.
- **#22/#32 two stage diameter switching**  
Dedicated chopper can switch between #22 and #32 heads to handle an extensive range of pack weights—from 80 to 800g.
- **Adjustable tray input width**  
Material width adjusting guide can adjust from 70 to 160mm.
- **Monitoring system**  
Equipped with monitoring system to ensure normal operation – immediately prior to meat feeding, sensors detect whether trays have been loaded or are overlapping. Equipped with automatic ground meat feeding level sensors to ensure stable delivery volume from the dedicated chopper.
- **Easy cleaning**  
Conveyor belt can be easily removed for cleaning.

## Features of the Fully Automatic Mince Packer Line (MP-117)

- **Labor-saving**  
Drastic labor reductions compared with conventional hand tray packing. Greatly increased maximum processing ability, from 40 to 70 packs per minute.  
※Compared with Nippon Career's previous MP-114. Note that figures will differ depending on tray shape and weight.
- **Hygienic**  
Mechanical packing ensures hygiene.
- **Dedicated chopper**  
Improved head precision and utilized years of knowhow accumulated by one of Japan's top grinder manufactures. In particular, increases in temperature are inhibited to preserve vivid material color and achieve undamaged meat quality.

[Image of Line Interlinkage]  
MP-117, TC-093, VC-301V, FMG-307P

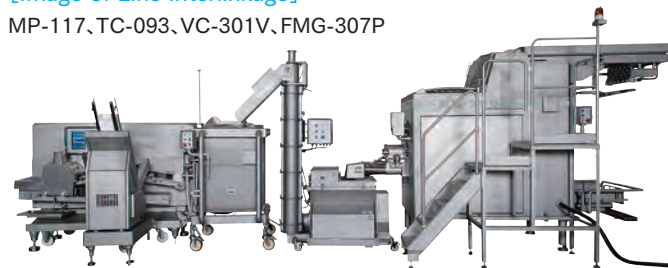

[Semi Automatic Line]

Mince Packer **MP-083**



## Features of the Semi-Automatic Mince Packer Line (MP-083)

- Easily maneuverable semi-automatic type perfect for wide variety, low volume production.
- Advanced chopper and integrated control identical to the MP-117 uniformly cuts meat to fixed lengths.



## Knife damage preventing Knife push design

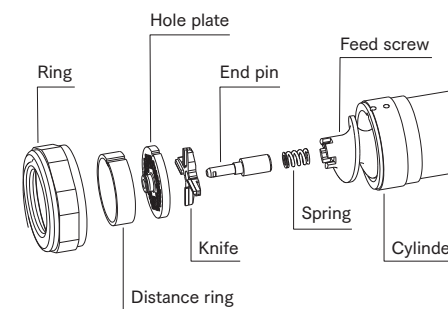

## Optional: Cartilage and sinew removal External automatic bone collector

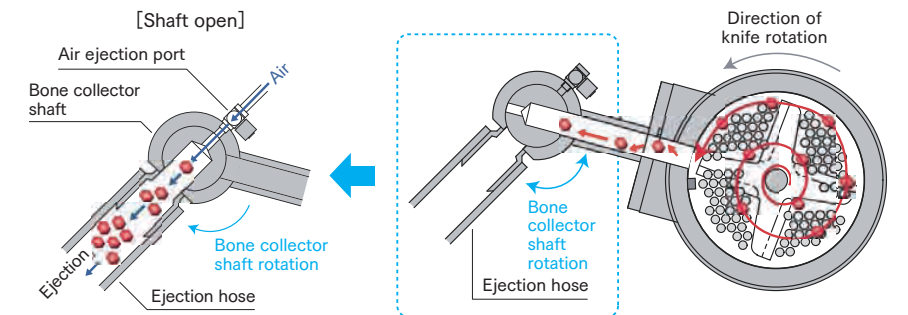

Minimum space, minimum transport distance – high efficiency flow maximizes product appeal.



MP-117



TC-093



Vertical conveyor



Mixer grinder



Vertical conveyor



Flaker



Flaker mixer grinder



Finished product



Fixed length cutting



Material conveyor



Ejection port



Dedicated chopper tub



Coarse ground meat after mixing



Coarse ground meat after mixing



Flaking



Frozen meat blocks